



# Designing Accessible Communities

## NEWSLETTER - WINTER 2011

The mission of Designing Accessible Communities (DAC) is to promote, facilitate and support the use of accessible design, accessible manufactured products and the implementation of policies which ensure that all individuals, regardless of age or disability, are able to participate fully in all aspects of our community and society. Designing Accessible Communities works with both design and construction professionals as well as the general public to bring awareness of the need for accessibility in the built environment.

### Safe Temporary Paths During Construction



An accessible sidewalk closure and alternate route.



An inaccessible sidewalk closure. No accessible signage for blind pedestrians. Caution tape is not an acceptable barricade.

Guest Article by Tim Cox, National Sales Manager, Plastic Safety Systems, Inc.  
[www.plasticsafety.com](http://www.plasticsafety.com)

If you remember anything about safe pedestrian pathways in construction work zones, remember these two words: "Accessible" and "Detectable."

In the context of pedestrian safety in work zones: "Accessible" describes a pathway through a work zone that pedestrians can safely reach, enter, and then move through to the end.

"Detectable" describes devices that pedestrians need for guidance to safely enter and traverse a pedestrian work zone, including "speak out" signage.

In practice, most pedestrian work zones are not sufficiently accessible or detectable. Most fall far short and are often difficult for those sighted and

mobile. Unsafe and inaccessible barricade systems make movement by pedestrians, especially those with limited vision or mobility, much more difficult.

It is imperative that we, as a society, protect everyone who travels the public rights of way. We achieve accessible and detectable pedestrian work zones through education, and good engineering and regulatory practices.

As most people know, the United States Access Board is the federal agency responsible for developing accessibility guidelines. In 2002, and again in 2005, the Access Board published draft guidelines in "Public Rights-of-Way Accessibility Guidelines" (PROWAG). Final draft guidelines were published this past summer.

*continued on page 2*

## Safe Paths, continued

Just as the pedestrian safety advocate routinely looks to PROWAG, the traffic safety professional reaches for the MUTCD, the Manual on Uniform Traffic Control Devices. Issued by the Federal Highway Administration (FHWA), MUTCD is the reference source for and repository of traffic control standards and guidelines. Most importantly, MUTCD has the force of law.

PROWAG mirrors MUTCD definitions for temporary pedestrian access routes. For example, in Section 302.4, PROWAG defines barricades and channelizing devices as "continuous, stable, non-flexible." It then references "devices from MUTCD." Similarly, the words "accessible" and "detectable" appear throughout the MUTCD.

Several MUTCD references are crucial to understanding, implementing and maintaining accessible pedestrian routes through work zones. Due to space limitations here, we offer a few examples:

### MUTCD 2009 References:

#### MUTCD Section 6D.02, Accessibility Considerations: Standard, line 3:

*When existing pedestrian facilities are disrupted, closed, or relocated in a TTC [temporary traffic control] zone, the*



*Left:  
An accessible, cane-detectable alternate route. (Arrow points to cane detectable horizontal portion of barricade.)*

*Right:  
An inaccessible non-continuous barrier that is not cane-detectable.*



*temporary facilities shall be detectable and include accessibility features consistent with the features present in the existing pedestrian facility.*

*Where pedestrians with visual disabilities normally use the sidewalk that is now closed, a barrier that is detectable by a person with a visual disability traveling with the aid of a long cane shall be placed across the full width of the closed sidewalk.*

#### MUTCD Section 6F.63, Channelizing Devices: Standard, line 4:

*Devices...shall be detectable to users of long canes and visible to persons having low vision.*

#### Standard, line 5:

*...there shall be continuous detectable bottom and top surfaces detectable to users of long canes...the bottom surface shall be no higher than 2" above the ground. The top of the top surface shall be no lower than 32" above the ground.*

Of course, neither PROWAG nor MUTCD limit the conversation to temporary traffic control devices. Of equal importance are: the pathway surface, in slope and texture; visible and audible signing; temporary ramps; and sidewalk closures.

All components contribute to the goal: safe, accessible and detectable pedestrian routes through construction zones.

The FHWA MUTCD can be found online at: [www.mutcd.fhwa.dot.gov/2009/pdf\\_index.htm](http://www.mutcd.fhwa.dot.gov/2009/pdf_index.htm)

Tim Cox joined Plastic Safety Systems in 2003 as a Regional Sales Manager. He is a veteran traffic safety professional, with 32 years in the industry.



Tim is a member of ATSSA (American Traffic Safety Services Association) and ARTBA (American Road Transportation Builders Association). He serves as the Secretary of the Temporary Traffic Control Technical Committee of the National Committee On Uniform Traffic Control Devices.

Tim is also a member of the Transportation Research Board (TRB) Committees AHB50, Traffic Control Devices, and AHB55, Work Zone Traffic Control.

Contact Tim at 216-244-3207 or [timcox@comcast.net](mailto:timcox@comcast.net)

# Code Interpretation

Guest Article by Chris Downey, [www.arch4blind.com](http://www.arch4blind.com)  
and BJ Dietz Epstein, [www.bjdepstein.com](http://www.bjdepstein.com)

Accessible paths and path widths are important features to assure that individuals using mobility devices and other pedestrians, including those who are blind, can safely traverse buildings and sites. There are other measurements that are important to safety in the accessible path as well.

Any object whose lower edge is between 27" and 80" above the finished floor may only protrude a maximum of 4" into the circulation path (2010 Americans with Disabilities Act Accessibility Guidelines (ADAAG), Section 307.2, and 2010 California Building Code, Title 24 (CBC) Section 1133B.8.6). If the object is a freestanding, post-mounted object, such as a sign or public telephone, it may extend 12" into the path (2010 ADAAG 307.3). This is to allow cane users with visual impairments to safely navigate the path. At these measurements, they will detect the protruding object with their cane before they run into it. These regulations also protect others traveling the path, such as someone looking down or getting distracted while walking. Their feet or legs would encounter the warning barrier before their head encountered the protruding object.

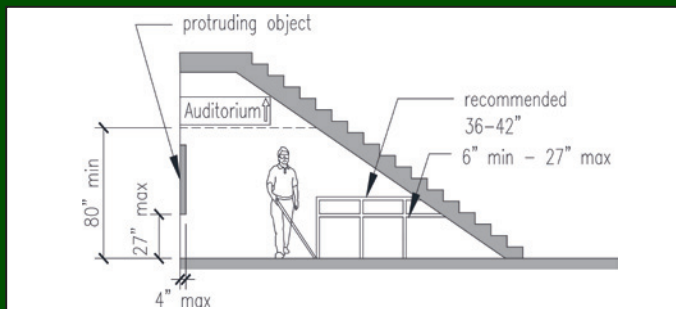

Diagram showing ADAAG and CBC measurements for protruding objects.

This may seem an easy task, to keep protruding objects out of the path and keep people out of harm's way. However, there are a few situations that regularly get overlooked.

Staircases, by their very nature, create a dangerous protruding object. Where the staircase is less than 80" overhead, there should be a guardrail or other

permanent barrier with its leading edge no more than 27" high (2010 ADAAG 307.4). Without this barrier, someone with a visual impairment could walk right into the underside of the stairs. Another form of obstruction that often eludes many architects and engineers is an inward sloping wall or structural element. If it slopes into walkable area and tilts out beyond 4" at an elevation of less than 80", it is a protruding object with low head clearance that would predictably result in a body blow, face plant or head banger as the object cannot be detected first with a cane. In these cases, a fixed permanent element is to be located under the sloped object that extends out horizontally to the extent needed to provide a barrier to at least the point where the sloped object is above 80" above the finished floor.



Left: Staircase without cane-detectable barrier. Right: Angled structural element.



Photos by Dwight Astrow

Another situation that frequently gets overlooked is low hanging plant branches. Tree limbs, if not properly maintained, can grow into the path of travel. Indoors, plants are often used as part of the décor. Large, freestanding potted plants may protrude into the path. Again, the danger is that someone with a visual impairment will run into the protruding object and get injured, all because the object was not cane-detectable. The simplest solution here is to remove the plant. The plant could also be trimmed back to protrude from its pot or tree pit no more than 4" into the path. A third option would be to create a cane-detectable barrier around the plant, either with a larger fixed planter, a guard rail, or some other fixed construction that provides a permanent barrier.

These are just a couple of examples of dangerously protruding objects. It is important to note that non-permanent objects, such as decorative plants, can

*continued on page 4*

## Code, continued

constitute a protruding object. Unlike barriers that prevent or restrict access to those with mobility impairments, failure to comply with the requirements for protruding objects and low head clearance can result in bodily harm including lacerations, bruises, broken bones or worse if a person walks into a protruding object and is knocked to the ground. These requirements are intended to secure safe passage. It is vital for everyone's safety and ease of use that the path of travel be kept clear of obstructions.



*Low-hanging tree branch.*

Chris Downey is an architect, planner and consultant who lost his sight in 2008. Today, he is dedicated to creating more helpful and enriching environments for the blind and visually impaired.

email: [chris.downey@arch4blind.com](mailto:chris.downey@arch4blind.com)

BJ Dietz Epstein is an accessibility consultant and architectural designer.

email: [bjdepstein@gmail.com](mailto:bjdepstein@gmail.com)

## DAC Newsletter Now Available on Website

Missed the last newsletter? Want to look up an article in a past issue? You can now find the Designing Accessible Communities Newsletters Archive on the website: <http://www.designingaccessiblecommunities.org/> Click on "Newsletter" on the far right in the navigation bar across the top.

Beginning with the Summer 2011 Newsletter, all newsletters will now be available in both an accessible PDF format and a screen-reader-friendly text-only file.

## Movie Theatres: A Sound Experience

by BJ Dietz Epstein, Accessibility Consultant/Architectural Designer  
[www.bjdepstein.com](http://www.bjdepstein.com)

Going to the movies is something many of us take for granted. The sights, the sounds, the buttered popcorn, all lend to the magical and exciting experience. Now imagine that you cannot hear. Being deaf and trying to watch a movie without captioning is not a magical thing, but something frustrating or even embarrassing.

Cinemark Holdings, Inc., one of the largest motion picture exhibitors in the world, with over 5000 screens worldwide, is planning a major change in how people who are deaf, or have some loss of hearing, watch movies. Though we do not have an exact date, we know that by mid-2012, Cinemark hopes to offer a closed captioning option at all of its first-run theatres. A number of theatres in California already offer this option.

Closed captioning provides people who are deaf and hard-of-hearing access to the significant audio content of a movie, not just the dialogue, but also non-spoken information, such as identity of the speaker(s), their manner of speaking, music, or sound effects.

Cinemark will transmit the closed captions via a personal display device, available upon request, that can be used at any seat. This change is being implemented as Cinemark converts their theatres to digital cinema. It also acts as response to the lawsuit filed in 2010 by California's Disabled Rights Advocates.

Designing Accessible Communities will be encouraging movie theatres across the country to work with equipment manufacturers to develop and install descriptive audio systems for individuals with blindness or low vision. We will have further information in a future Newsletter.

---

BJ Dietz Epstein is an architectural designer with a specialty in accessibility. Ms. Epstein earned her Masters of Architecture from Iowa State University, and has 6 years experience with accessibility in the built environment.  
email: [bjdepstein@gmail.com](mailto:bjdepstein@gmail.com)

# Proposed Shared Streets Project in SF

by Richard Skaff, Chris Downey, and BJ Dietz Epstein

On October 24th, 2011, Neil Hrushowy, Alexis Smith, and David Winslow of the San Francisco Planning Department met with Richard Skaff of Designing Accessible Communities (DAC), Chris Downey of Architecture for the Blind, and BJ Dietz Epstein, an accessibility consultant, to discuss an upcoming shared streets project. The Jefferson Street and Fisherman's Wharf area are the location for the project, which was first proposed almost four years ago. There was a desire to rethink the area for the next fifty years and transform it into a world class destination for locals and tourists alike.

The current volume of pedestrians in the area is some 70,000 - 110,000 people per day. People are already overflowing the sidewalks and walking in the streets, a dangerous situation for both pedestrians and drivers. Though the area has a number of businesses that require vehicle access for some part of the day, most of this traffic would not interfere with day usage by pedestrians. Restaurants and other local businesses on Jefferson Street would be able to receive their deliveries via truck or other vehicle until about 11 am. After that time, the two blocks from Powell to Taylor would be closed to most vehicular traffic for the remainder of the main daytime hours. Buses and streetcars would still run through the area, and other vehicular access would be restricted to 100 or fewer vehicles per hour, with a reduced speed to ensure pedestrian safety.

The proposal is still in its earliest stages, and is just getting the funding and the design team together now. Neil Hrushowy and his associates were very open when speaking with us about the challenges associated with making the shared streets accessible and safe for everyone, including people with mobility, vision, or hearing disabilities.

People with vision impairments will be particularly affected. The concept of shared streets is built around the idea of eye contact between the motorist, the cyclist, and the pedestrian to negotiate passage. Blind and visually impaired pedestrians cannot participate in this eye contact negotiation. Blind or visually impaired pedestrians who use guide dogs or canes to navigate the public right of way will have difficulty navigating on streets based on the present shared streetscape concepts. Without curbs to alert their guidedogs or detect with their cane so they will not enter the traffic lanes, those with limited or no sight are at risk and may not even know it. Silent hybrid and electric vehicles at slow speeds compound the problem, as they may not

be heard to alert the non-sighted pedestrian of their presence.

Similar shared streets projects in other communities around the world have met with resistance from the blind community, as the areas have been found to be dangerous, frustrating, and difficult to navigate. Many people with limited vision have stated that they tend to avoid such areas.

However, the San Francisco Planning Department believes in the power of design to solve problems, and hopes that, with continued conversations with and feedback from the disability community in San Francisco, they will be able to design a safe, accessible, and pleasing area. In the future, there will be two rounds of public meetings to discuss the shared streets design concepts. DAC will be closely monitoring the project as it develops.

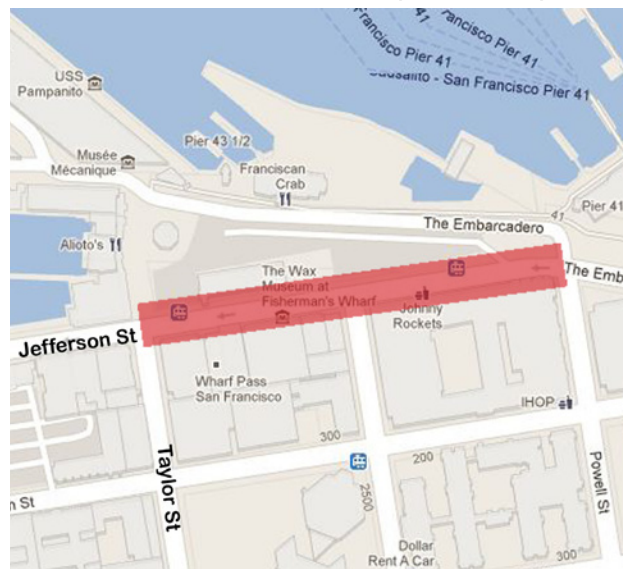

Map of proposed shared streets area: Jefferson St. between Powell and Taylor, indicated with red rectangle.

Richard Skaff is the founder/Executive Director of Designing Accessible Communities.  
 email: richardskaff@designingaccessiblecommunities.org  
 Chris Downey is an architect, planner and consultant who lost his sight in 2008.  
 email: chris.downey@arch4blind.com  
 BJ Dietz Epstein is an architectural designer with a specialty in accessibility.  
 email: bjdepstein@gmail.com

# Accessible Table Bases

Guest Article by David Brush, Owner, Tablebases  
www.tablebases.com

Lately we at Tablebases.com have been working with Designing Accessible Communities, a non-profit organization that promotes policies and products for accessible design, to identify table bases that can be used to create wheelchair accessible tables for restaurants and other public accommodations.

Despite the fact that there have been state building code requirements since the 1970's and Federal regulations since 1991 requiring wheelchair accessibility in public places, there continues to be confusion about these requirements. The California Building Code, Title 24 (CBC) are the state building codes relating to accessibility, and the Americans with Disabilities Act (ADA) is a Federal civil rights law that prohibits the exclusion of people with disabilities from everyday activities. The 2010 CBC and the 2010 ADA Standards for Accessible Design require that at least 5% of the seating spaces within dining, banquet and bar areas in restaurants must be wheelchair accessible. Dining surfaces include, but are not limited to, bars, tables, lunch counters, and booths. This means that 1 out of every 20 tables or dining surfaces in a restaurant must be accessible for patrons in a wheelchair. It also means that if there is a separate bar or banquet area, each area must have the required number of accessible tables. Small restaurants and cafes are not exempted from the regulations; if the restaurant or bar has less than 20 tables, at least 1 must be accessible. (See p. 9 for State Architect interpretation.)

An accessible table has a clear area under the table that is at least 19" deep by 30" wide and 27" high from

the finished floor. It is recommended that the clearance under the table be 29" tall to serve persons using larger electric wheelchairs. The surface of the table top must be between 28" and 34" above the floor. The clear area under the table cannot have any obstruction that will interfere with either the wheelchair or the knees and feet of the patron.

For smaller round or square tables, bolt-down bases are usually the best solution if you can permanently mount them in place. The bolt-down bases have the smallest footprint and therefore the least amount of interference.

For rectangular tables a pair of T Style Bases will work well. The bases must be placed so that there is at least 30" clear width between them.

Using tables with 4 vertical legs is a good choice for larger round, square or rectangular tables. Square and rectangular tables with 4 vertical legs also allow for putting tables together in different configurations to serve larger parties, a benefit in busy restaurants.

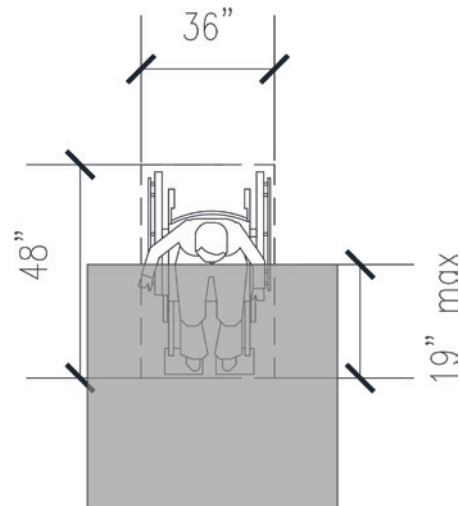

Diagram showing 2010 ADA and 2010 CBC required measurements for an accessible table, with lap covered. (plan view)

Above is a plan view drawing to show the requirements within both the CBC and the ADA Accessibility Guidelines. The 30" x 48" area can include the 19" that extends under the table that was described earlier.

In addition to the accessible tables themselves, there must be an accessible route to the accessible tables and throughout the restaurant dining rooms and bars

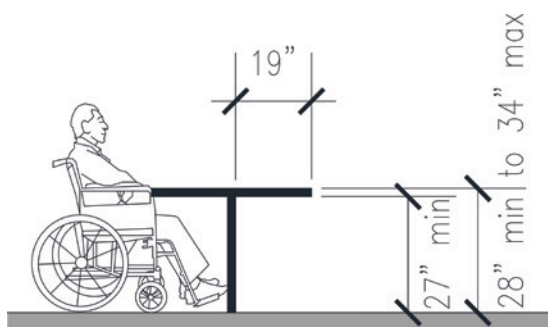

Diagram showing 2010 ADA and 2010 CBC required measurements for an accessible table where a wheelchair user can sit with lap covered.

continued on page 7

## Table Bases, continued

that assures that people using mobility devices are able to navigate to and through the dining room, bar, and banquet areas as well as to restrooms. This is a 36" wide path, even with people seated at tables.

Besides being a legal requirement, a lot of the restaurateurs I talk with understand that it is good business to accommodate all of their potential customers. It is also simply the right thing to do.

David Brush is the owner of Tablebases.com, the premier internet seller of table bases, restaurant chairs, and table tops. Tablebases strives to have the best variety of high quality table bases available. They have been selling high quality table bases to our customers since 2000. See their website or call 1-800-258-2320 to learn more about their accessible products. email: david@tablebases.com



Accessible: 4 vertical legs on a round table top. Ensure that the clear width between legs is 30" minimum.



Accessible: Tablebases' Eclipse Stainless Steel Bolt-Down Table Base. The small footprint keeps the base from interfering with patrons' legs and wheelchair footrests. Ensure that there is at least 19" from the edge of the table top to the center pole.



Accessible: A center pole table with a flat base. The base plate on this table must be 1/2" or less in order to be accessible.

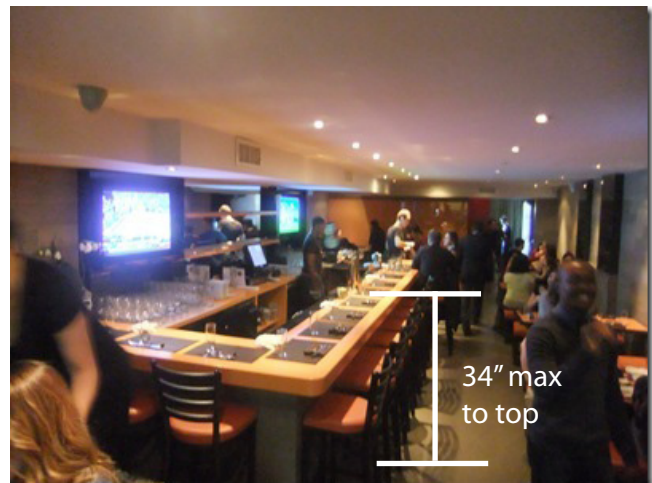

Accessible bar (upper) and bar section (lower): The bar tops are at 34" from the finished floor with the required 27" knee clearance below.

continued on page 8



*Inaccessible Table: Though this table may have the required measurements for table top height and knee clearance, the fixed bench seating does not allow for someone using a wheelchair to pull up to the table, as there is not a minimum 30" clearance between the benches.*

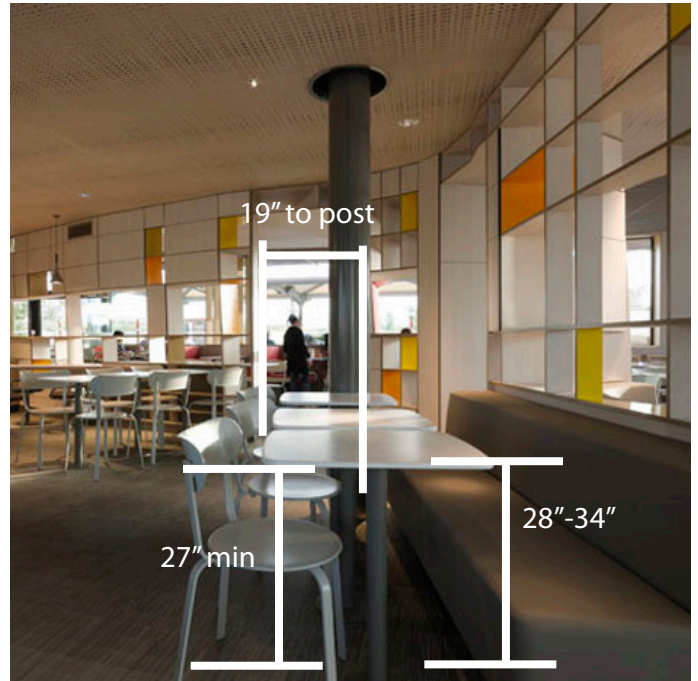

*Accessible Tables: Though there is bench seating along one side of these tables, with the required clearances, they may still be accessible on the moveable chair side. Provide a 27" tall by 19" deep knee clearance with the table top at 28" to 34". Remember to leave a 30" by 48" clear space for a wheelchair to pull up to the table.*

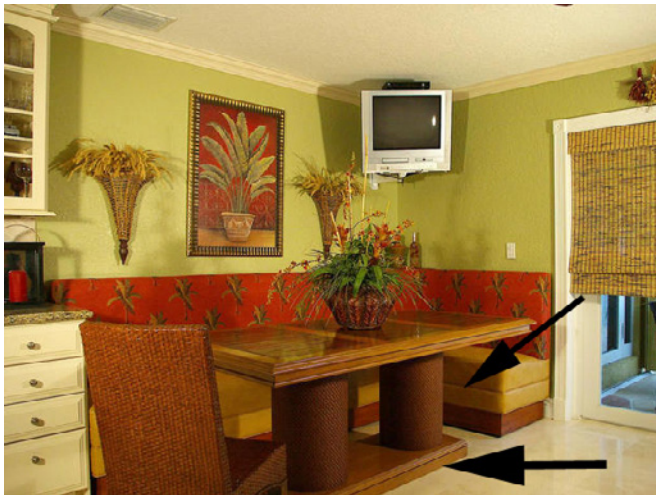

*Inaccessible Table: This table does not have the required knee clearance underneath due to the large pedestals and thick base upon which the table rests.*



*Accessible T Style Table base: Provide 30" clear width between the two T Style bases to ensure accessibility. Also make sure that there is a minimum 27" knee clearance below the table and that the top is no more than 34" from the finished floor.*



*Inaccessible Table Base: This table base is not accessible because the X-shaped bottom may interfere with wheelchairs with fixed foot rests.*



## ACCESSIBLE SEATING AT FIXED COUNTERS

95-09

Reference: 2001 California Building Code Sections 1104B.5 item 4, 1122B.4 &amp; 1134B.2

Effective 10-31-95  
Revised 8-25-05

This policy is applicable to projects under Division of the State Architect, Access Compliance (DSA/AC) jurisdiction only; this authority encompasses state-funded buildings, facilities and universities, as well as publicly funded elementary schools, secondary schools, and community colleges. Local authorities may or may not adopt similar methods of administering current code requirements, determining equivalent facilitation or defining acceptable parameters when enforcing the California Building Standards Code. [Reference California Government Code Section 4451(f)]

**Issue:** At fixed counters exceeding 34 inches (864 mm) in height, when food or drink is served for consumption by customers seated on stools or standing at the counter, table service at accessible tables within the same area had been an acceptable alternative to providing accessible seating at the fixed counter. As of April 1, 1994, providing table service instead of accessible seating at a fixed counter is no longer an option in California. California Building Code (CBC) Section 1104B.5 item 4 indicates that each dining, banquet and bar area shall have one wheelchair seating space for each 20 seats, with at least one minimum wheelchair seating space per functional area. In addition, required accessible seating areas shall be integrated with general seating areas to avoid having one area specifically *highlighted* as the area for persons with disabilities. Where fixed counters are provided for the public, CBC Section 1122B.4 indicates that at least 5 percent, but never less than one, of each type of station shall be located at a section of counter that is at least 36 inches (914 mm) long. However, seating for one at a lowered section of counter does not provide the disabled person with an equal opportunity to sit shoulder-to-shoulder with others and converse. Federal accessibility guidelines require that where food or drink is served at fixed counters exceeding 34 inches (864 mm) in height, an accessible portion of counter 60 inches (1524 mm) in length minimum be provided.

**Resolution:** At dining, banquet, and bar facilities, accessible seating spaces shall be integrated with general seating to avoid having one area specifically *highlighted* as the area for persons with disabilities. At fixed counters exceeding 34 inches (864 mm) in height, where food or drink is served for consumption by customers seated on stools or standing at the counter, the DSA encourages and will accept designs that indicate accessible portions of counters designed to accommodate more than one person, allowing disabled persons an equal opportunity to converse with others.

Under the provisions of CBC 1134B.2, when it is determined that compliance with accessibility regulations in existing buildings or facilities would create an unreasonable hardship, an exception may be granted when equivalent facilitation is provided. An example of equivalent facilitation would be to provide an accessible counter or bar with similar architecture, casework, ambience and service, in close proximity to the existing counter or bar, which will accommodate several people. Some existing buildings or facilities have historic significance which may allow use of the State Historical Building Code. Projects will be evaluated by the DSA on a case-by-case basis to ensure both accessibility and an equitable environment are provided to the maximum extent feasible.

*The Board of Directors of DAC wants to thank the San Francisco Independent Living Resource Center for its support for this project through a grant from the Herb Levine Legacy Fund.*



Independent Living Resource Center  
San Francisco